

CONTROL SYSTEMS SOCIETY

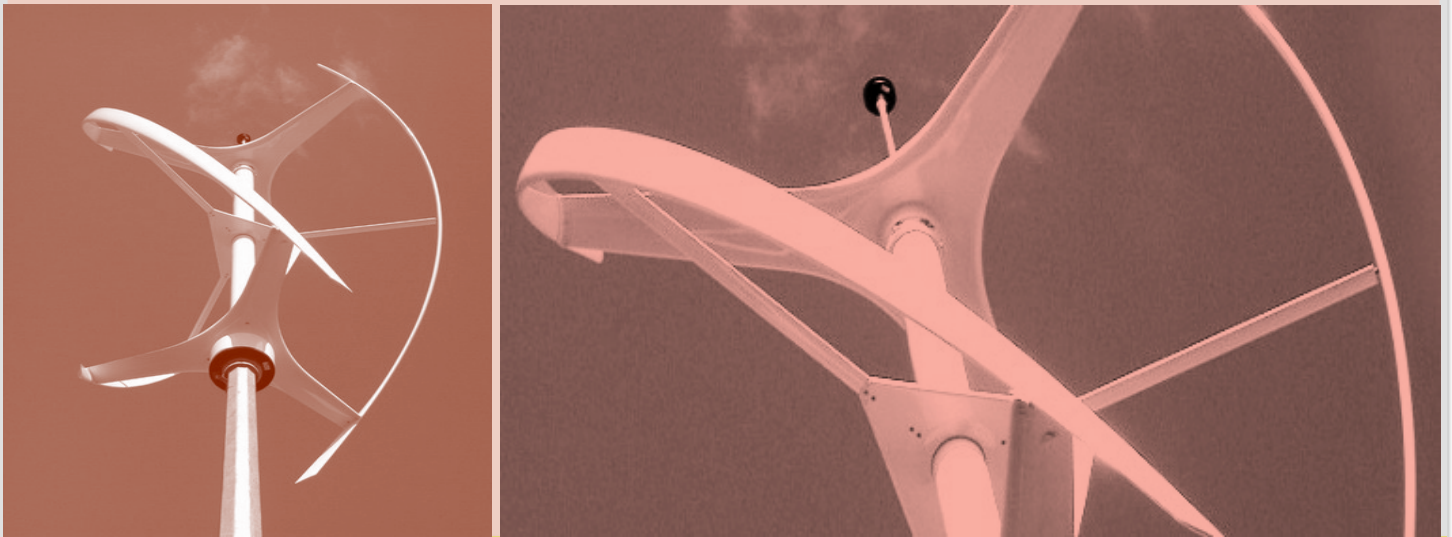

PUBLICATIONS CONTENT DIGEST

Publications Activities

Vice-President

THOMAS PARISINI *Imperial College, UK*

<http://www.ieeecss.org/publications/css-publications>

Journal Editors

IEEE Transactions on Automatic Control

PANOS J. ANTSAKLIS *University of Notre Dame*

<http://www.ieeecss.org/publications/tac>

IEEE Transactions on Control Systems Technology

ANDREA SERRANI *Ohio State University*

<http://www.ieeecss.org/publications/tcst>

IEEE Transactions on Control of Network Systems

IOANNIS PASCHALIDIS *Boston University*

JEFF SHAMMA Deputy Editor-in-Chief *King Abdullah University of Science and Technology*

<http://www.ieeecss.org/publications/transactions-control-network-systems>

IEEE Control Systems Magazine

JONATHAN HOW *Massachusetts Institute of Technology*

<http://www.ieeecss.org/publications/csm>

Electronics Editor

E-letter on Systems, Control and Signal Processing

JIANGHAI HU *Purdue University*

<http://www.ieeecss.org/publications/e-letter/e-letter>

*Submission and editorial instructions can be found on each publication's homepage

For subscription to the monthly E-Letter, please visit:

<http://www.ieeecss.org/newsletter/subscriptions>

IEEE TRANSACTIONS ON AUTOMATIC CONTROL

A PUBLICATION OF THE IEEE CONTROL SYSTEMS SOCIETY



APRIL 2017

VOLUME 63

NUMBER 4

IETAA9 (ISSN 0018-9286)

[Table of Contents](#)

[Full Text: PDF](#)

[IEEE Transactions on Automatic Control](#)

[Publication information](#)

[Full Text: PDF](#)

[Scanning the Issue](#)

[Full Text: PDF](#)

Full Papers

[Decentralized Q-Learning for Stochastic Teams and Games](#)

G. Arslan, S. Yuksel

[Abstract](#) | [Full Text: PDF](#)

[Integral Action in Output Feedback for Multi-Input Multi-Output Nonlinear Systems](#)

D. Astolfi, L. Praly

[Abstract](#) | [Full Text: PDF](#)

[Robust Linear Static Anti-Windup with Probabilistic Certificates](#)

S. Formentin, F. Dabbene, R. Tempo, L. Zaccarian, S. M. Savaresi

[Abstract](#) | [Full Text: PDF](#)

[Distributed Continuous-Time Convex Optimization with Time-Varying Cost Functions](#)

S. Rahili, W. Ren

[Abstract](#) | [Full Text: PDF](#)

[Convergence of Self-Organizing Pulse Coupled Oscillator Synchronization in Dynamic Networks](#)

J. Klinglmayr, C. Bettstetter, M. Timme, C. Kirst

[Abstract](#) | [Full Text: PDF](#)

[Regularity and Lyapunov Stabilization of Weak Entropy Solutions to Scalar Conservation Laws](#)

S. Blandin, X. Litrico, M. L. Delle Monache, B. Piccoli, A. Bayen

[Abstract](#) | [Full Text: PDF](#)

[A Convex Sum-of-Squares Approach to Analysis, State Feedback and Output Feedback Control of Parabolic PDEs](#)

A. Gahlawat, M. M. Peet

[Abstract](#) | [Full Text: PDF](#)

[Finite-Time Consensus on the Median Value with Robustness Properties](#)

M. Franceschelli, A. Giua, A. Pisano

[Abstract](#) | [Full Text: PDF](#)

[Distributed Coordination of Dynamical Multi-agent Systems Under Directed Graphs and Constrained Information Exchange](#)

A. Abdessameud, I. G. Polushin, A. Tayebi

[Abstract](#) | [Full Text: PDF](#)

[Dissipativity Theory for Nonlinear Stochastic Dynamical Systems: Input-Output and State Properties, and Stability of Feedback Interconnections](#)

T. Rajpurohit, W. M. Haddad

[Abstract](#) | [Full Text: PDF](#)

[On the Synthesis of Boundary Control Laws for Distributed Port Hamiltonian Systems](#)

A. Macchelli, Y. Le Gorrec, H. Ramirez, H. Zwart

[Abstract](#) | [Full Text: PDF](#)

Sparse Resource Allocation for Linear Network Spread Dynamics

J. Abad Torres, S. Roy, Y. Wan
Abstract | Full Text: PDF

Networked State Estimation over a Shared Communication Medium

M. Xia, V. Gupta, P. J. Antsaklis
Abstract | Full Text: PDF

Robust Stabilization of Uncertain Time-Delay Systems with Fractional Stochastic Noise Using the Novel Fractional Stochastic Sliding Approach and its Application to Stream Water Quality Regulation

K. Khandani, V. J. Majd, M. Tahmasebi
Abstract | Full Text: PDF

Solving the Infinite-Horizon Constrained LQR Problem using Accelerated Dual Proximal Methods

G. Stathopoulos, M. Korda, C. N. Jones
Abstract | Full Text: PDF

An Optimized Algorithm of General Distributed Diagnosability Analysis for Modular Structures

Lina Ye, Philippe Dague
Abstract | Full Text: PDF

Feedback Refinement Relations for the Synthesis of Symbolic Controllers

G. Reissig, A. Weber, M. Rungger
Abstract | Full Text: PDF

The Invariant Extended Kalman Filter as a Stable Observer

A. Barrau, S. Bonnabel
Abstract | Full Text: PDF

Marking Observer in Labeled Petri Nets with Application to Supervisory Control

M. P. Cabasino, C. N. Hadjicostis, C. Seatzu
Abstract | Full Text: PDF

A Characterization of Switched Linear Control Systems with Finite L_2 -Gain

Y. Chitour, P. Mason, M. Sigalotti
Abstract | Full Text: PDF

Intermittent Redesign of Analog Controllers via the Youla Parameter

L. Mirkin
Abstract | Full Text: PDF

A Novel a priori State Computation Strategy for the Unscented Kalman Filter to Improve Computational Efficiency

S. K. Biswas, L. Qiao, A. G. Dempster
Abstract | Full Text: PDF

Semidefinite Programming Approach to Gaussian Sequential Rate-Distortion Trade-offs I

T. Tanaka, K-Ki K. Kim, P. A. Parrilo, S. K. Mitter
Abstract | Full Text: PDF

Extremum Seeking for Static Maps with Delays

T. R. Oliveira, M. Krstic, D. Tsubakino
Abstract | Full Text: PDF

Technical Notes and Correspondence

Output Feedback Stabilization for Discrete-Time Systems under Limited Communication

Y. Feng, X. Chen, G. Gu
Abstract | Full Text: PDF

Adaptive Sliding Mode Control of Markov Jump Nonlinear Systems with Actuator Faults

H. Li, P. Shi, D. Yao
Abstract | Full Text: PDF

Observer Design for Parameter Varying Differentiable Nonlinear Systems, with Application to Slip Angle Estimation

Y. Wang, R. Rajamani, D. M. Bevly
Abstract | Full Text: PDF

A Tool for the Global Stabilization of Stochastic Nonlinear Systems

T. Bian, Z-P. Jiang
Abstract | Full Text: PDF

Accuracy Improvement of Extremum Seeking Control

K. Atta, A. Johansson, T. Gustafsson
Abstract | Full Text: PDF

Trajectory Tracking Control of Planar Underactuated Vehicles

H. Ashrafiuon, S. Nersesov, G. Clayton
Abstract | Full Text: PDF

Robust Stability Analysis and Synthesis for Uncertain Discrete-Time Networked Control Systems Over Fading Channels

L. Su, G. Chesi
Abstract | Full Text: PDF

A Missing Data Approach to Data-Driven Filtering and Control

I. Markovskiy

Abstract | Full Text: PDF

The Cooperative Output Regulation Problem of Discrete-Time Linear Multi-Agent Systems by the Adaptive Distributed Observer

J. Huang

Abstract | Full Text: PDF

Relay Control Design for Robust Stabilization in a Finite-Time

A. Polyakov, L. Hetel

Abstract | Full Text: PDF

Fault Tolerant Corrective Control With Bounded Delays

J-M. Yang

Abstract | Full Text: PDF

Distributed Feedforward Approach to Cooperative Output Regulation Subject to Communication Delays and Switching Networks

M. Lu, L. Liu

Abstract | Full Text: PDF

Conic Bounds for Systems Subject to Delays

L. J. Bridgeman, J. R. Forbes

Abstract | Full Text: PDF

Consensus of Quantum Networks with Directed Interactions: Fixed and Switching Structures

G. Shi, S. Fu, I. R. Petersen

Abstract | Full Text: PDF

Passivity-Based Asynchronous Control for Markov Jump Systems

Z-G. Wu, P. Shi, Z. Shu, H. Su, R. Lu

Abstract | Full Text: PDF

Boundary Control of Coupled Reaction-Advection-Diffusion Systems with Spatially-Varying Coefficients

R. Vazquez, M. Krstic

Abstract | Full Text: PDF

Scaling in Bidirectional Platoons with Dynamic Controllers and Proportional Asymmetry

I. Herman, D. Martinec, Z. Hurak, M. Sebek

Abstract | Full Text: PDF

Myopic Allocation Policy with Asymptotically Optimal Sampling Rate

Y. Peng, M. C. Fu

Abstract | Full Text: PDF

Minimum Variance Distortionless Response Estimators For Linear Discrete State-Space Models

E. Chaumette, P. Benoit, F. Vincent, G. Pages, A. Dion

Abstract | Full Text: PDF

Iterated Posterior Linearisation Smoother

A. F. García-Fernandez, L. Svensson, S. Sarkka

Abstract | Full Text: PDF

Deadlock Analysis of Parameterized-Chain Networks

M. H. Zibaeenejad, J. G. Thistle

Abstract | Full Text: PDF

Event-triggered Adaptive Control for a Class of Uncertain Nonlinear Systems

L. Xing, C. Wen, Z. Liu, H. Su, J. Cai

Abstract | Full Text: PDF

» FEATURES



66



82

» DEPARTMENTS



14

Cover credit: Highlighting the high-assurance control issues for cyberphysical systems (courtesy Nicola Bezzo). Inset: Prof. Rudolf Kalman (photo courtesy of the National Academy of Engineering, United States).

66 Design and Implementation of Attack-Resilient Cyberphysical Systems

With a focus on attack-resilient state estimators

MIROSLAV PAJIC, JAMES WEIMER, NICOLA BEZZO, OLEG SOKOLSKY, GEORGE J. PAPPAS, and INSUP LEE

82 High-Assurance SPIRAL

End-to-end guarantees for robot and car control

FRANZ FRANCHETTI, TZE MENG LOW, STEFAN MITSCH, JUAN PABLO MENDOZA, LIANGYAN GUI, AMARIN PHAOSAWASDI, DAVID PADUA, SOUMMYA KAR, JOSÉ M.F. MOURA, MICHAEL FRANUSICH, JEREMY JOHNSON, ANDRÉ PLATZER, and MANUELA M. VELOSO

104 Adversarial Testing to Increase the Overall Security of Embedded Systems

A review of the process

ERIC THAYER

109 Formal Methods for Control of Traffic Flow

Automated control synthesis from finite-state transition models

SAMUEL COOGAN, MURAT ARCAK, and CALIN BELTA

129 Hierarchical Game Theory for System-Optimal Control

Applications of reverse Stackelberg games in regulating marketing channels and traffic routing

NOORTJE GROOT, GEORGES ZACCOUR, and BART DE SCHUTTER

3 FROM THE EDITOR

Letters of Reference

5 ABOUT THIS ISSUE

High-Assurance Control

14 PRESIDENT'S MESSAGE

The Control Problem

17 CSS NEWS

18 25 YEARS AGO

19 MEMBER ACTIVITIES

Membership Trends and Standing Committees

22 PUBLICATION ACTIVITIES

An Update on Society Publications

25 TECHNICAL ACTIVITIES

An Update on Technical Activities

Technical Committee on Hybrid Systems

Technical Committee on Systems Biology

31 APPLICATIONS OF CONTROL

Application-Oriented Input Design in System Identification

57 PEOPLE IN CONTROL

Katsuhisa Furuta

Kingsley Fregene

Sebastián Dormido

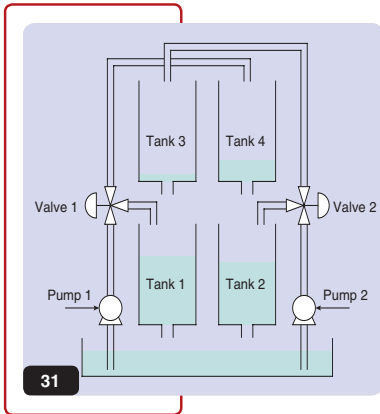

31

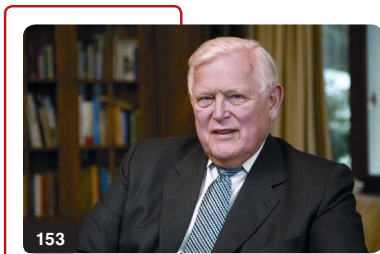

153



153 HISTORICAL PERSPECTIVES

A Tribute to Rudolf Kalman
 From Differential to Algebraic Riccati Equations: The Influence of Kalman
 Kalman's Influence on My Scientific Work: Some Recollections and Reflections
 My Experiences with Rudolf Kalman
 Memories of Rudy Kalman
 Rudolf Kalman: Scientist, Leader, and Mentor
 The Legacy of Rudolf Kalman—What I Learned from Him
 Rudolf E. Kalman: The Father of Mathematical Systems Theory
 Kalman: The Scientist Who Defined Our Field
 Rudy Kalman, As I Knew Him
 States of Linear Systems, Automata, and Marriage
 Prof. R.E. Kalman—A Personal Tribute
 R.E. Kalman, The Man Who Laid the New Foundations of Control Science, Opening Up Grand Unexplored Horizons
 To Rudolf E. Kalman: A Personal Goodbye
 Kalman's Last Decade: Passive Network Synthesis
 Remembering Prof. R.E. Kalman and His Center for Mathematical System Theory
 Encounters and Interactions with Rudolf E. Kalman

181 BOOKSHELF

Principles of System Identification: Theory and Practice
Iterative Learning Control: An Optimization Paradigm
 Book Announcements

190 CONFERENCE REPORTS

The 13th International Workshop on Discrete Event Systems
 The 35th Chinese Control Conference
 The 10th Multi-Conference on Systems and Control
 The Third International Conference on Control and Fault-Tolerant Systems

201 CONFERENCE CALENDAR

204 ON THE LIGHTER SIDE
 At the Dynamical Systems Dealership

**IEEE PERIODICALS
 MAGAZINES DEPARTMENT**

445 Hoes Lane, Piscataway,
 NJ 08854 USA

Senior Managing Editor
 Geraldine Krolin-Taylor

Senior Art Director
 Janet Dudar

Associate Art Directors
 Gail A. Schnitzer, Mark Morrissey

Production Coordinator
 Theresa L. Smith

Advertising Production Manager
 Felicia Spagnoli

Production Director
 Peter M. Tuohy

*Director, Business Development –
 Media & Advertising*
 Mark David

Editorial Director
 Dawn M. Melley

*Staff Director
 Publishing Operations*
 Fran Zappulla

IEEE prohibits discrimination, harassment,
 and bullying. For more information, visit
[http://www.ieee.org/web/aboutus/whatis/
 policies/p9-26.html](http://www.ieee.org/web/aboutus/whatis/policies/p9-26.html).

MISSION STATEMENT AND SCOPE: As the official means of communication for the IEEE Control Systems Society, *IEEE Control Systems Magazine* publishes interesting, useful, and informative material on all aspects of control system technology for the benefit of control educators, practitioners, and researchers. With this mission statement in mind, *IEEE Control Systems Magazine* encourages submissions, both feature articles and columns, on all aspects of control system technology.

SUBMISSION OF MANUSCRIPTS: A feature article typically provides an in-depth treatment of either an application of control technology, a tutorial on some area of control theory, or an innovation in control education.

IEEE Control Systems Magazine publishes a variety of columns. "Applications of Control" columns are industrially oriented summaries of innovations in control technology. "Focus on Education" typically describes some aspect of education such as novel control experiments. "Lecture Notes" can be theoretical in nature as long as they have clear tutorial value and intent. See recent issues for examples of these and other types of columns. Authors are encouraged to contact the editor-in-chief about the suitability of potential columns.

A detailed Author's Guide, a sample formatted manuscript, and LATEX template can be found at <http://www.ieeeccs.org/publications/csm/submissions>. The specifications in this Guide should be followed by all submissions.

All manuscripts should be submitted electronically to the *IEEE Control Systems Magazine* website, <https://css.paperplaza.net/conferences/scripts/start.pl>, with inquiries on appropriateness of content emailed to jhow@mit.edu.

SPECIAL ISSUES: *IEEE Control Systems Magazine* encourages proposals for special issues. Proposers are encouraged to contact the editor-in-chief to discuss potential topics.

BOOKS AND CONFERENCES: Submit information about recently published books to the associate editor for book reviews. Submit information about past and future conferences to the corresponding editor for conferences.

ADVERTISING: *IEEE Control Systems Magazine* accepts advertising for educational products, books, software, conferences, employment, and control-related technology. For information about advertising, contact Mark David, m.david@ieee.org, +1 732 465 6473.

IEEE CONTROL SYSTEMS MAGAZINE—(ISSN 1066-033X) (ISMA7) is published bimonthly by The Institute of Electrical and Electronics Engineers, Inc. Headquarters: 3 Park Avenue, 17th Floor, New York, NY 10016-5997, U.S.A. +1 212 419 7900. Responsibility for the contents rests upon the authors and not upon the IEEE, the Society, or its members. The magazine is a membership benefit of the IEEE Control Systems Society, and subscriptions are US\$4.00 per member per year (included in Society fee). Replacement copies for members are available for US\$20.00 (one copy only). Nonmembers can purchase individual copies for US\$103.00. Nonmember subscription prices are available on request. Copyright and Reprint Permissions: Abstracting is permitted with credit to the source. Libraries are permitted to photocopy beyond the limits of the U.S. Copyright law for private use of patrons: 1) those post-1977 articles that carry a code at the bottom of the first page, provided the per-copy fee indicated in the code is paid through the Copyright Clearance Center, 222 Rosewood Drive, Danvers, MA 01970, U.S.A.; and 2) pre-1978 articles without fee. For other copying, reprint, or republication permission, write to: Copyrights and Permissions Department, IEEE Service Center, 445 Hoes Lane, Piscataway NJ 08854, U.S.A. Copyright © 2017 by The Institute of Electrical and Electronics Engineers, Inc. All rights reserved. Periodicals postage paid at New York, NY and at additional mailing offices. Postmaster: Send address changes to *IEEE Control Systems Magazine*, IEEE, 445 Hoes Lane, Piscataway, NJ 08854 U.S.A. Canadian GST #125634188

Printed in U.S.A

Upcoming IEEE Conferences

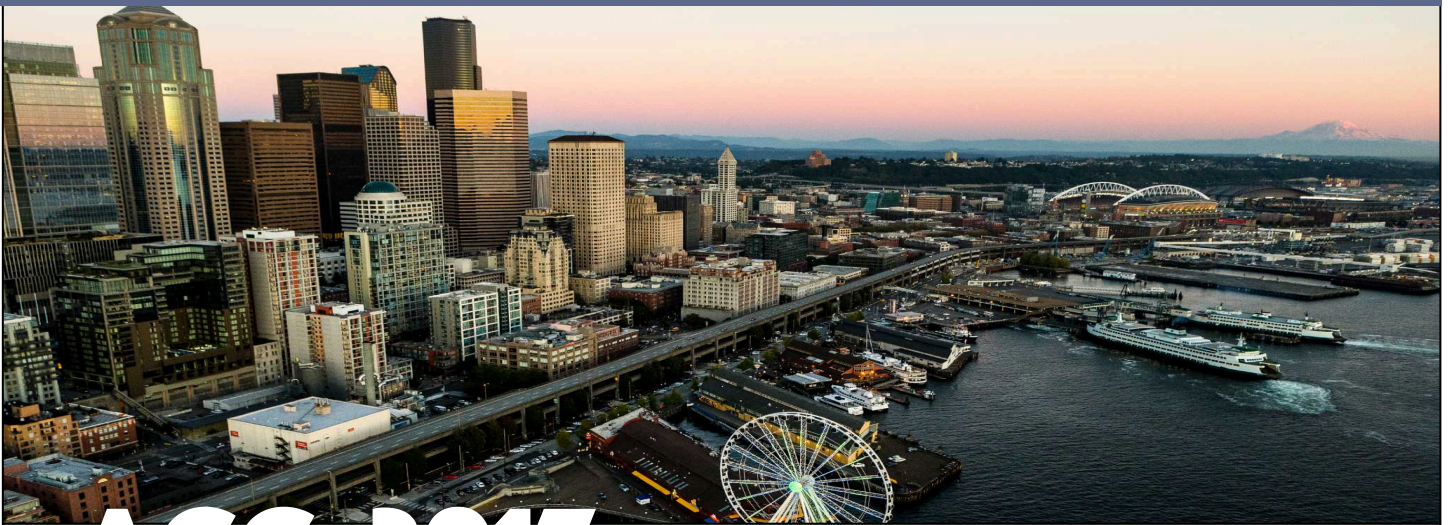

ACC 2017

Important Dates

Draft Manuscripts:

~~September 19, 2016~~ (*PASSED*)

Best Student Paper Nominations:

~~September 30, 2016~~ (*PASSED*)

Workshop Proposals:

~~October 10, 2016~~ (*PASSED*)

Acceptance/Rejection Notice:

~~January 15, 2017~~ (*PASSED*)

Final Manuscript Submission:

~~February 28, 2017~~ (*PASSED*)

2017 AMERICAN CONTROL CONFERENCE

**MAY 24-26, 2017
SEATTLE, WA, USA**

The 2017 American Control Conference will be held Wednesday through Friday, May 24-26 at the [Sheraton Seattle Hotel](#), centrally located in the heart of downtown Seattle, WA. Sheraton Seattle Hotel is near nightlife, restaurants, shopping, and entertainment, just a walk to all of Seattle's known sights such as the Seattle Waterfront, Pike Place Market, Space Needle, Seattle Aquarium, and the Washington State Ferries.

<http://acc2017.a2c2.org/>

December 12-15, 2017
Melbourne, Australia

2017 IEEE Conference on Decision and Control



Important Dates

January 4, 2017: Submission Site Opens (Passed)

March 20, 2017: Initial Paper Submissions Due (Passed)

May 1, 2017 Workshop Proposals Due

Mid-July Paper and Workshop Decision Notification

August 1, 2017: Final Submission Open and Registration Opens

September 20, 2017: Accepted Papers Due



CCTA 2017

Important Dates

Paper Submissions Open:
~~December 15, 2016~~ (Passed)

Invited Session Proposals Due:
~~March 1, 2017~~ (Passed)

Contributed and Invited Papers Due:
~~March 1, 2017~~ (Passed)

Acceptance Notice:
June 1, 2017

Final Submissions Due:
July 1, 2017

2017 CONFERENCE ON TECHNOLOGY AND APPLICATIONS

AUGUST 27-30, 2017
KOHALA COAST, HI, USA

CCTA 2017 will be held at the Mauna Lani Bay Hotel and Bungalows on the Big Island. The venue is a medium-sized, serene property on the west Kohala Coast, and the organizers have negotiated reasonable room rates which include all resort amenities. The Big Island of Hawai'i offers an abundance of natural beauty and sites, with 11 of the world's 13 climate zones. With a land mass of nearly twice the size of all other Hawaiian Islands combined, but with only a small fraction of the state's population, its diverse terrain spans green and black sand beaches to lush rainforests, waterfalls and active volcanoes.

<http://ccta2017.ieeecss.org/>